

**THIS BULLETIN APPLIES TO ALL DAVCO PRODUCTS WITH CLEAR COVERS**

Most field issues associated with leaks are related to loose fittings. These leaks are easily eliminated by checking and torquing the fuel fittings in the area of the leak. Some fittings may also require the application of liquid Teflon sealer.

**NOTE:** All suction side fuel filters experience bubbles. It is normal to see champagne size bubbles in the fuel processor at the Fuel Pro outlet or at the lift pump.

**IN ORDER TO RETURN A FUEL PROCESSOR FOR EVALUATION, THE FOLLOWING PROCEDURES/TESTS NEED TO BE COMPLETED BEFORE REQUESTING A DAVCO RGA (RETURN GOODS AUTHORIZATION).**

- I. **Air Leak:** Air bubbles will be visible in the clear cover of the Fuel Processor if the leak originates from the fuel tank up to the fuel filter. The following is a quick test to isolate the air leak source.
  - A. **Bubbles Visible:** Remove the Fuel Processor inlet hose.
    - i. Install a jumper hose from the Fuel Processor to the fuel tank (through the fill cap) or to a container of fuel.
    - ii. Start the engine. If this eliminates the air bubbles, the air source is at the fuel tank fittings or hose connections.
      1. Tighten all fittings and connectors
      2. Retest
    - iii. If air bubbles persist, the air source is on the Fuel Processor side of the system:
      1. Tighten all fittings on the Fuel Processor.
      2. Tighten the bottom collar (if applicable) with a collar wrench or a strap wrench and hand tighten the top collar.
      3. If the drain valve is suspected, install a plug place of the drain valve (for test purposes only).
    - iv. If air bubbles continue to persist, test as follows:
      1. Remove the Fuel Processor from the chassis.
      2. Plug fuel outlet port as shown in adjacent drawing. Do not remove filter, cover/collar, vent cap, drain valve and/or check valve. If the Fuel Processor is equipped with a preheater, do not remove the preheater. Do not plug fluid heat ports. (See drawings on next page.)
      3. Apply 15PSI of air pressure at the fuel inlet. Immerse the Fuel Processor in a tank of water and look for air bubbles.
      4. Correct the source of the air leak and retest.
  - B. **Bubbles Not Visible:** If there are symptoms of sucking air (indicated by engine loping/rough running performance/power loss, etc.) and there are no bubbles in the clear cover, the air leak is either at the Fuel Processor outlet fitting, vent cap o-ring, the lift pump inlet connection, or the fuel hose/connections to the lift pump. Inspect and tighten fittings as needed.
- II. **Excessive Restriction:** If the fuel level is at the top of the filter, replace the fuel filter. The Fuel Processor will not cause excess system restriction if the fuel level is below the top of the filter. The only exception is if the grommet is not installed in the bottom of the filter element.
- III. **Loss of Prime:** When air is introduced into the fuel system, (ie: draining water from the Fuel Processor or when replacing the fuel filter) a check valve is needed to keep the fuel system primed from the Fuel Processor back to the fuel tank. A check valve is standard with all on-highway Fuel Processors. A check valve needs to be added by the equipment manufacturer for Industrial Pro's and Sea Pro's.
  - A. To test for proper check valve operation, remove the fuel inlet hose and open the vent cap. Fuel should not flow out of the Fuel Processor, although a slight seepage of fuel is normal.
  - B. If fuel drains back to the fuel tank, remove the check valve assembly at the fuel inlet fitting. Disassemble the check valve assembly. Clean, inspect and replace the assembly if any cuts, grooves or nicks are evident in the ball or body seat ([www.davcotec.com](http://www.davcotec.com) for check valve assembly part number information). Reinstall the check valve assembly.

**Diesel Pro 232 - 233**

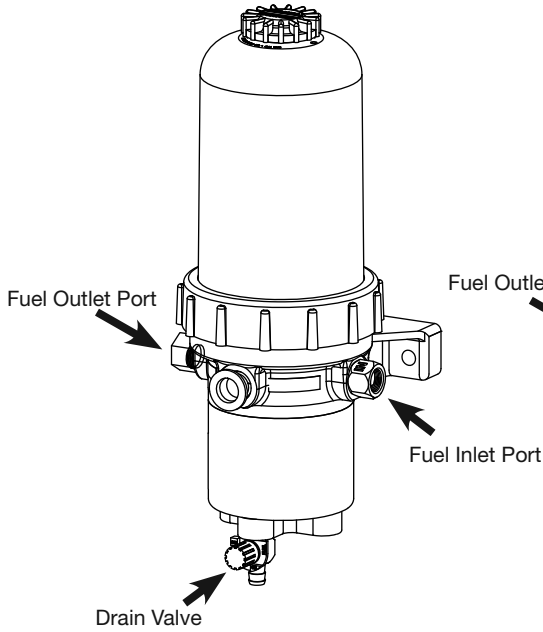

**Fuel Pro 382**

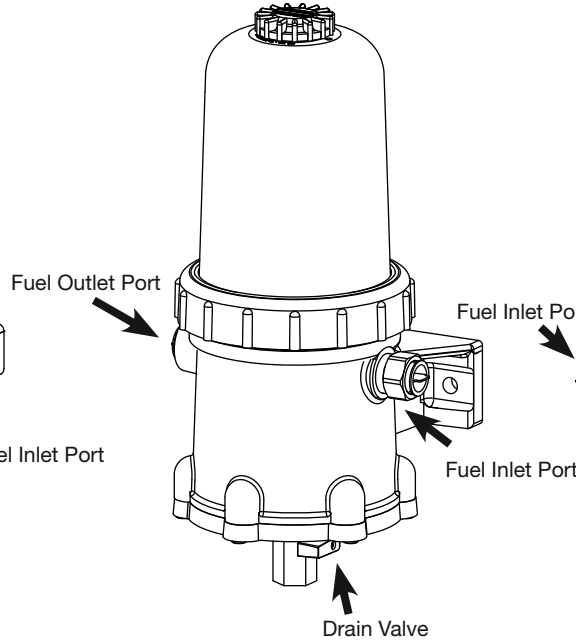

**Fuel Pro 482**

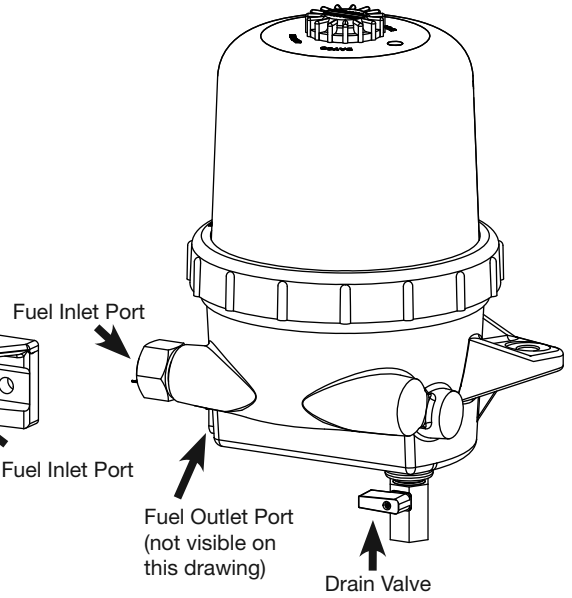

**Industrial Pro Single**

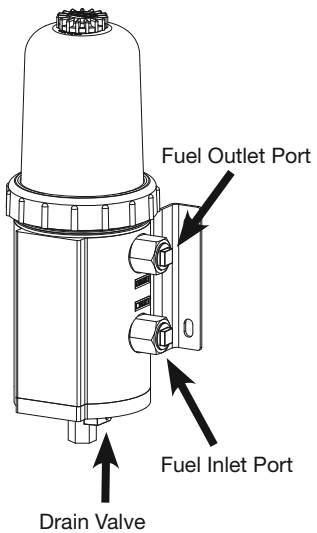

**Industrial Pro Dual**

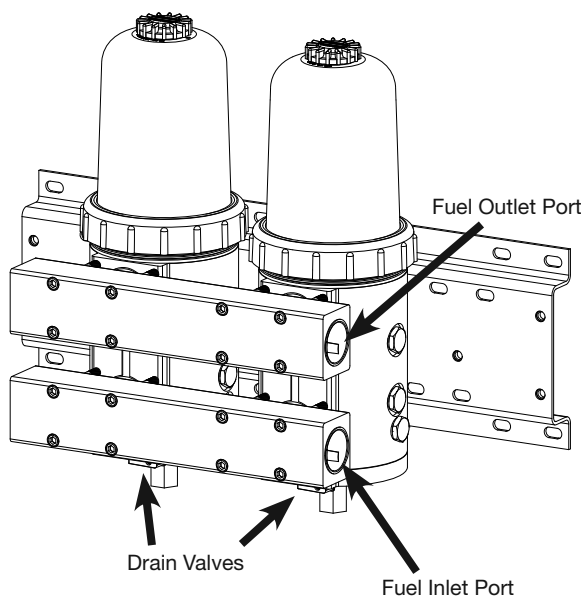

**Sea Pro Duplex**

