

Installation Instructions for the Diesel Pro® 233 Unheated Filter / Separator / Heater System

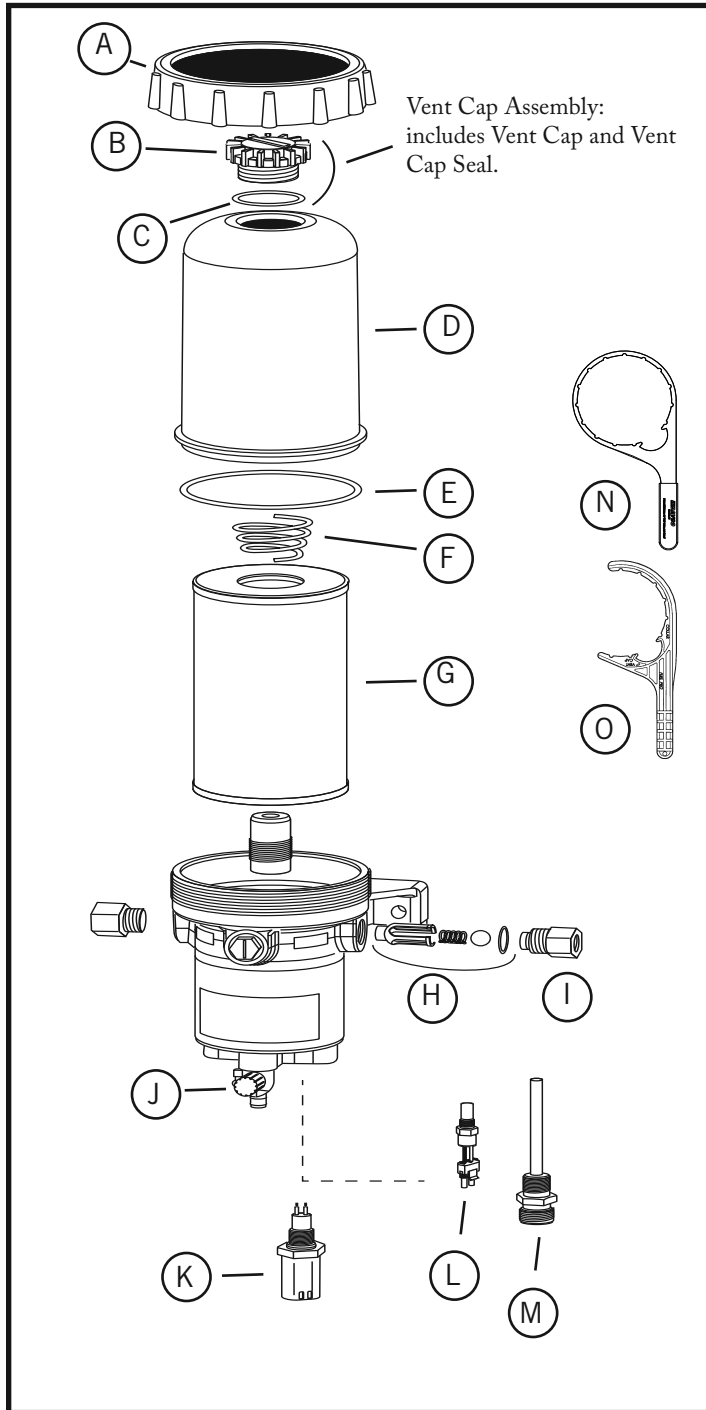

- A. Collar (part no. 232001)
- B. Vent Cap (part no. 380043)
- C. Vent Cap Seal (part of Kit 232009)
- D. Cover (part no. 233000)
- E. Cover Seal (part of Kit 232009)
- F. Filter Spring (part no. 380056)
- G. Filter Element
- H. Check Valve Service Kit (part no. 101824)
- I. Check Valve (part no. 101930)
- J. Drain Valve (part no. 101332)
- K. Water In Filter (WIF) Sensor (part no. 102507)
- L. 12 V / 24 V Electric Heater/Thermo Combo
 (12 VDC - part no. 102438)
 (24 VDC - part no. 102439)
- M. 120 VAC Electric Heater (part no. 101813)
- N. Collar Wrench - metal (part no. 232007DAV)
- O. Collar Wrench - composite (part no. 232002)

CAUTION: These instructions are intended for use by professional mechanics who are trained in the proper use of power and hand tools, using appropriate safety precautions (including eye protection).

Diverter Cap Part Number	Required Filter Head Stud Size	Required Filter Head Seal ID	Required Filter Head Seal OD
101480	1"-14	2.475"	2.895"
101589	1"-14	3.225"	3.435"
102226	M16 x 1.5	2.475"	2.895"
101466	3/4" x 16	2.475"	2.895"
101492	7/8" x 14	2.475"	2.895"
101721	M18 x 1.5	2.475"	2.895"
101592	13/16" x 12	3.225"	3.235"

TABLE 1

Service Kit Installation

This system must be installed between the fuel tank and the transfer fuel pump. This system can be used as **the only fuel filter in the fuel system** by removing the existing filter and heads, or remove the filters only and replace with special Diverter Caps.

Note: If the Diesel Pro® is used as the primary filter and a secondary filter is required, secondary filter life may be extended.

⚠ WARNING: When diesel fuel is circulated through an operating engine, it can become very hot. To prevent personal injury:

- Scalding hazard! Do not allow heated liquid fuel to come in contact with eyes or unprotected skin. Always allow the engine and fuel to cool to ambient temperature before replacing the fuel filter or performing service operations which could result in the spillage of fuel from the fuel system. If this is not possible, protective clothing (face shield, insulated hat, gloves, apron) must be worn.
- Heated diesel fuel can form combustible vapor mixtures in the area around the fuel source. To eliminate the potential for fire, keep open flames, sparks or other potential ignition sources away from the work area, and do not smoke during filter replacement or service operations which could result in the escape of diesel fuel or fuel vapors.
- Always perform engine or vehicle fuel system maintenance in a well ventilated area that is kept free of bystanders.

Installation of the Diesel Pro Service Kit

Step 1 - With the engine shut down and at ambient temperature, close the fuel shutoff valve (if equipped) and place a suitable container under the fuel filters.

Step 2 - Remove the primary fuel filter element assembly, sedimenter, and/or water separator. Drain the used element and dispose of it in an environmentally responsible manner, according to state and/or federal (EPA) recommendations. The fuel can be returned to the tank.

Step 3 - For a one-filter system, select the required secondary filter head diverter cap from those listed in Table 1. The required part number is determined by the size of the spin-on filter stud and the filter sealing surface diameter.

Install the diverter cap on the secondary filter head as follows:

- a. Remove the secondary fuel filter filter element, drain and dispose of it in an environmentally responsible manner according to government regulations (i.e., state/province, federal, etc.). The fuel can be returned to the tank.
- b. Lightly lubricate the seal on the top of the diverter cap with clean engine oil.
- c. Thread the adapter onto the secondary filter stud and tighten by hand only.
- d. Install the "Do Not Remove" sticker on the diverter cap.

Step 4 - Mount the Diesel Pro in the desired location keeping the following points in mind:

- a. **Mounting the Diesel Pro directly on the engine is NOT RECOMMENDED.**
- b. Mount vertically with the cover and element pointing up.
- c. Make sure there is enough top and side clearance for the cover to be conveniently removed for filter replacement.

⚠ CAUTION: The Diesel Pro MUST be installed so that the Filter Element is above the "FULL" level of the fuel tank. If mounted below full tank level, a shut off valve will be required at the inlet to allow filter changes without overflow of fuel.

Step 5 - Route fuel lines as follows (see Figure 1):

- a. Route the fuel supply line from the pick up on the fuel tank to the Diesel pro inlet (labeled "Fuel In").
- b. Route the fuel outlet line from the Diesel Pro outlet (labeled "Fuel Out") to the inlet of the fuel pump. See Figure 1.

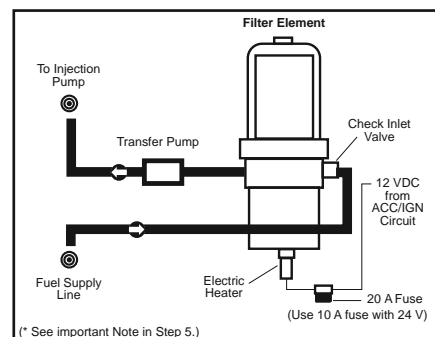

FIGURE 1

Step 6 - To minimize restrictions, observe the following guidelines when plumbing the system.

- Keep the fuel line routing as smooth as possible with no low hanging loops which can trap water.
- Use 90° elbows only when necessary.
- If the fuel hoses are made up to length on the job, be sure that the inner liner of the fuel hose is not cut by the fitting, creating potential check valve effects. Also make sure hoses are clean and free of debris before installing.

⚠ CAUTION: To avoid damaging the aluminum fuel processor body, do not overtighten fuel lines or fuel line fittings.

Step 7 - If an electrical pre-heater is required, see the “Installing an Electrical Heater” section.

Step 8 - If a Diesel Pro fluid heated model is installed, the fuel processor should be plumbed so that the radiator fluid (coolant) flow to the Diesel Pro is controlled to prevent the fuel rise. Using 5/8" ID premium heater hose and clamps, tap into the hot side of the radiator coolant system for supply to the Diesel Pro. Connect the coolant return line from the Diesel Pro to the cool side of the radiator coolant system. Either of the 5/8" hose barbs at the base of the Diesel Pro can be used for coolant supply or return.

Note: Mechanical tightening is not required and may distort or crack the filter head.

Installing a WIF (Water In Fuel) Probe

Step 1 - Install the WIF Probe (102507) into the bottom of the Diesel Pro (see Figure 2).

Step 2 - Install the WIF wiring harness on WIF Probe. The harness has the following connections: 12" (304.8 mm) black ground lead with a 3/8" (9.53 mm) diameter loop end and a 72" (1828.80 mm) green WIF wire.

Step 3 - Drill 1/2" (12.70mm) hole in the dash or control panel where the WIF LED is to be located.

Step 4 - Install WIF LED by pressing firmly into the drilled hole.

Step 5 - Connect the 4" (101.60 mm) black ground wire on WIF LED to a ground source. Attach additional black wire as needed.

Step 6 - Connect the 12" (304.8 mm) black ground lead with a 3/8" (9.53 mm) diameter loop end on the WIF

wiring harness to ground source near Fuel Processor (if applicable).

Step 7 - Connect the 72" (1828.80 mm) green signal wire on WIF wiring harness to 4" (101.60 mm) green signal wire on WIF LED. Use additional green wire as needed.

Step 8 - Locate 12 VDC or 24 VDC power source. Run red wire from power source to 4" (101.60 mm) red wire on WIF LED. Add a 10 A in-line fuse (not included).

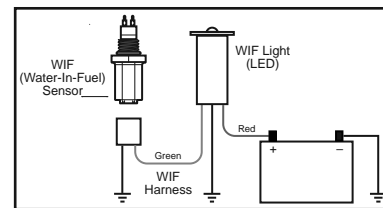

FIGURE 3

Note: Use appropriate connectors to attach the wires. To test the WIF indicator, pour water into the body of the fuel processor until it covers the WIF probe. The WIF LED should illuminate. For unheated fluid, the volume of fluid necessary to turn the WIF indicator on is 3.65 oz ± .07 oz (108 mL ± 2 mL), for heated fluid the volume necessary is 3.38 oz ± .07 oz (100 mL ± mL).

Installing an Electric Heater

The Diesel Pro can use either an Electric Heater / Thermo-Switch combination unit or a 120 V / 37 W **To install a heater-thermo Combo unit:**

Step 1 - If the Heater-thermo Combo unit (1) is not already installed, remove the 1/2" NPT plugs from the bottom plate of the Diesel Pro and install the Heater-Thermo Combo unit. Torque to 15-30 ft-lbs (20.3-40.7 N·m).

Step 2 - Connect the Chassis-Ground Harness (4) to the Fuel Processor Harness.

Step 3 - Connect the Power Lead to the accessory side of the ignition switch. (Use of a 20 A fuse is recommended but not included in the Diesel Pro kits. Use a relay if the equipment ignition circuit will not handle a minimum of 20 A. (See figure 5).

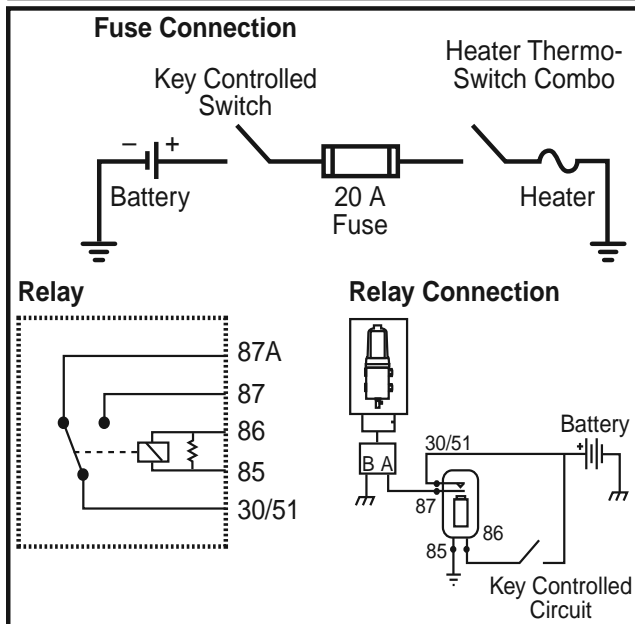

Figure 5

(supplied with the filter) is installed on the vent cap. Re-install the vent cap and **tighten by hand only**.

Step 7 - Start the engine. when the lubrication system reaches its normal operating pressure, increase engine speed to high idle for two to three minutes.

Step 8 - After the air is purged, and the engine is running, loosen the vent cap. When the fuel level falls to the top of the collar, quickly tighten the vent cap.

Note: The clear filter cover will not fill completely during engine operation. It will gradually fill over time as the filter becomes clogged. The filter element does not need to be changed until the fuel level has risen to the top of the filter element.

Filter Change Procedure

Step 1 - Turn off the engine. Loosen the vent cap to break the air lock in the filter.

Step 2 - Open the drain valve and drain the fuel level below the collar, then close the drain valve.

Step 3 - Using the Collar/Vent Cap Wrench (part number 232002 (composite) or 232007 DAV (metal)), remove the clear cover from the fuel processor by removing the collar. Discard the o-ring from the base of the cover. (A new o-ring seal is supplied with the new filter). Remove the filter element from the Diesel Pro® by pulling upward and twisting slightly. Be sure the sealing grommet is removed from the center stud.

Step 4 - Fill the fuel processor with clean diesel fuel through the elongated hole at the top. **Do not fill through the center stud opening.** This is the filtered fuel outlet to the fuel pump.

Step 5 - Install the new filter element (supplied with a Sealing Grommet already inserted into the element) on the processor center stud by pushing down and twisting slightly. After checking to make sure the new o-ring seal (supplied with the filter) at the base of the cover is in place, install the cover and collar. **Hand tighten** the collar until seated. **Do not use tools to tighten.**

Step 6 - Remove the vent cap from the top of the clear cover by turning the vent cap counterclockwise. Fill the clear cover full of clean fuel. Make sure the new o-ring

Preparation of the Diesel Pro Fuel Processor for Service

The Diesel Pro fuel processor must be filled with clean fuel before the filtering system will operate properly. Use the following procedure to prepare the Diesel Pro for service.

Step 1 - Loosen the vent cap. Use the Collar/Vent Cap Wrench (see Figure 6) if necessary, and remove the vent cap.

Step 2 - Fill the fuel processor body and cover with new, clean diesel fuel through the vent cap opening on the top up to the top "Change Filter" Stripe on the filter.

Step 3 - Check to make sure the o-ring seal is installed on the vent cap, then reinstall the vent cap and tighten by hand.

Step 4 - Open the fuel shutoff valve, if installed, and start the engine. When the lubrication system reaches its normal operating pressure, increase engine speed to high idle for 2 to 3 minutes. Visually check the filter installation for leaks, and retighten the collar or vent cap by hand, as required.

Step 5 - With the engine running, loosen the vent cap on the clear cover. The fuel level in the cover will start falling. When the fuel level falls to the top of the collar, tighten the vent cap quickly by hand.

Step 6 - If any fuel fitting leaks were found in Step 5, shut down the engine and retighten fittings, as required.

Note: The clear filter cover will not fill completely during engine operation. It will gradually fill over time as the filter becomes clogged. The filter element does not need to be changed until the fuel level has risen to the top of the filter element.

Suggested Preventive Maintenance

Every Filter Change - Change o-rings and grommet (included with new filter).

Every 12 Months - Check all electrical connections for corrosion. Check all fuel fittings for leaks.

Extreme winter or salt corrosion environments may require lubrication of the top collar threads with Loctite® 76747 anti seize every 180 days

