

DAVCO Technology, LLC

TABLE OF CONTENTS

How it Works	1
“Seeing is Believing®”	2
Important Safety Precautions	3
Fuel Pro 382 Dimensions	4
Fluid Heater Installation	7
12 VDC and 24 VDC Electric Pre-heater Installation	8
Water in Fuel Sensor (WIF) Installation	9
Preventive Maintenance.	10
Filter Change Procedure	11
Visual Diagnostics	12
Diagnostic Procedures	14
Diagnostic Procedures	16
Check Valve Diagnostics	17
Service Parts	18
Warranty and Customer Service	21

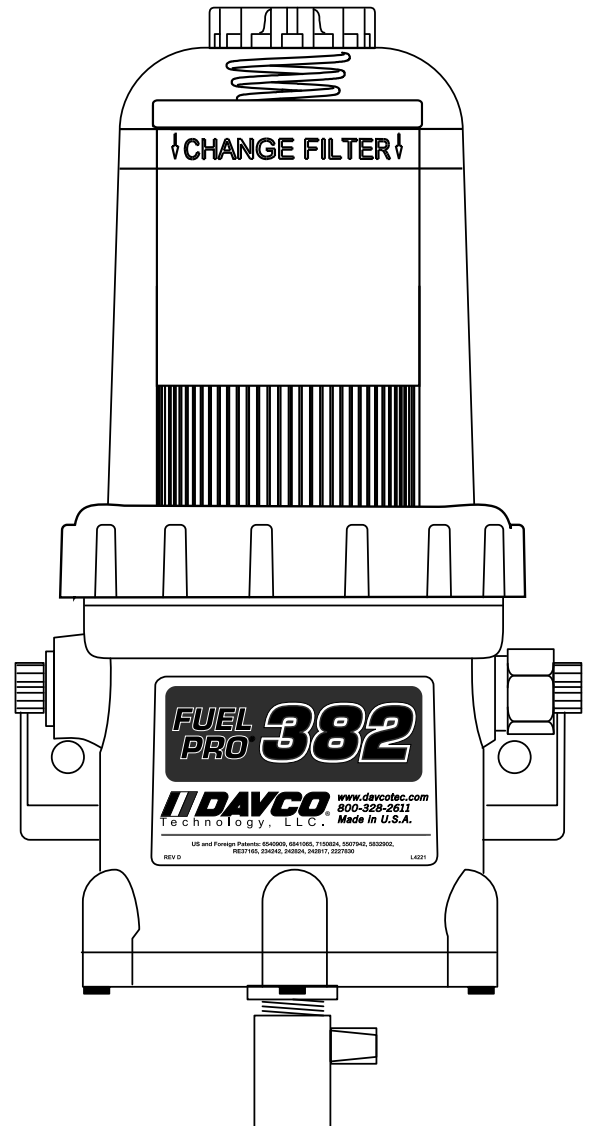

FOR UPDATED INFORMATION, VISIT WWW.DAVCO.COM

FUEL PRO[®] 382 **TECHNICAL MANUAL**

HOW IT WORKS

- Fuel from the tank enters the Fuel Processor body (suction side of the fuel system).
- Large contaminants and “free” water are separated from the fuel and remain in the body.
- Fuel rises into the clear cover.
- Contaminants and emulsified water are captured by the filter media.
- Fuel level rises to maintain a fuel path through the clean filter media with low restriction.
- Clean, water-free fuel exits the Fuel Processor and flows to the engine fuel injection system.

Fuel System Diagram

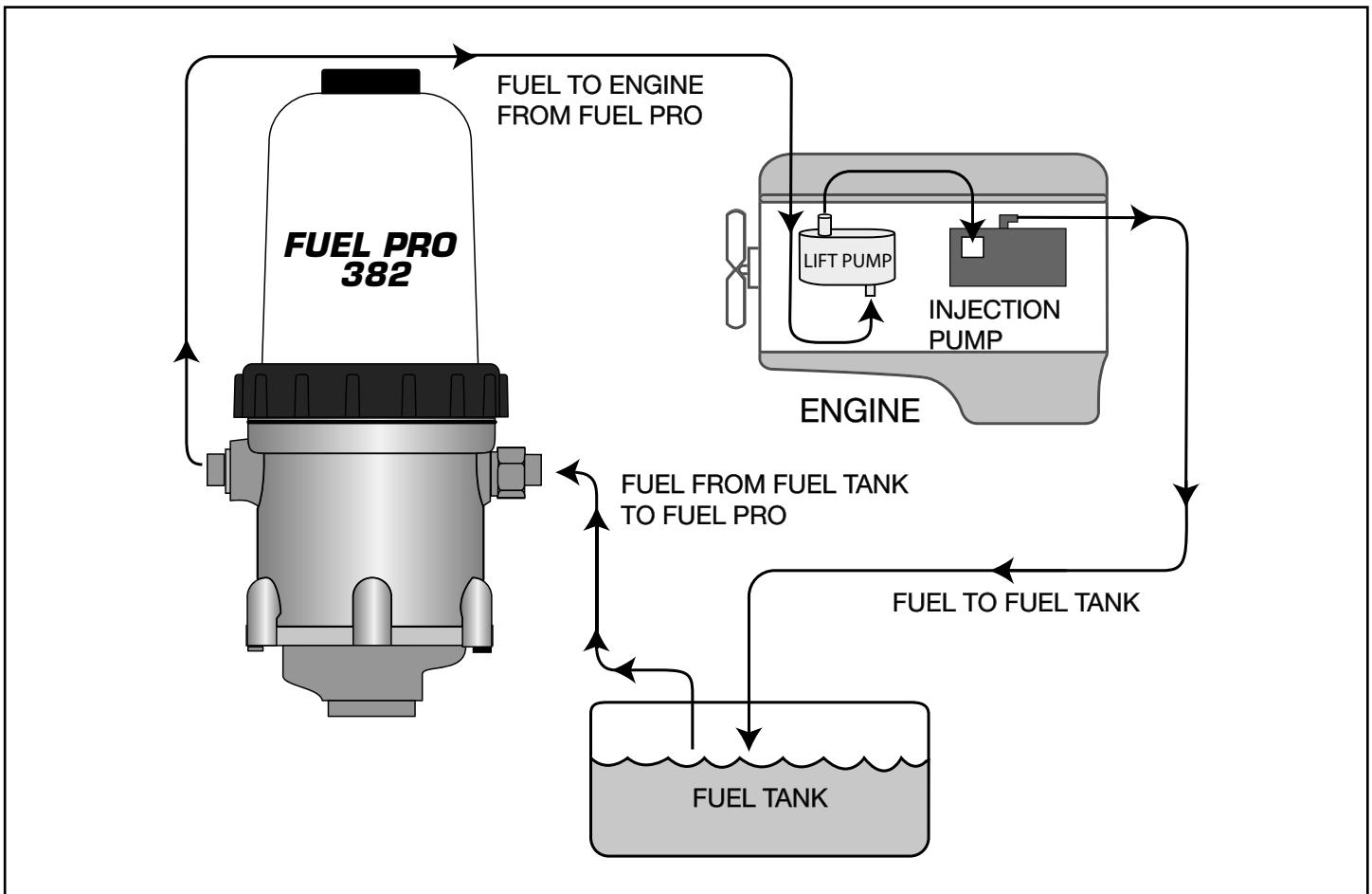

Figure 1

“SEEING IS BELIEVING®”

- **See when NOT to change the fuel filter.**
- **See the condition of the fuel.** Seeing what collects on the filter media or what’s happening inside the clear cover can help diagnose many fuel and mechanical conditions.
- **“Filter on Top” configuration.** Water and debris removed from the fuel falls to the lower chamber and stays away from the filter media resulting in longer filter life.
- **Built in protection when priming the fuel filter.** Unfiltered fuel is kept on the “dirty” side of the filter media during priming ensuring only clean fuel reaches the engine.
- **Patented media.** The “Best in Class” StrataPore™ media removes 98% of free and emulsified water over the life of the filter. This far exceeds the performance of cellulose media.



When new, the fuel level in the filter will be very low with minimal restriction. As the filter is used, contaminants collect on the filter from the bottom up. Fuel rises on the filter indicating remaining filter life.



Fuel level increases in clear cover. As contaminants collect on the filter, the fuel rises to a non-contaminated section of the filter, providing optimal filtration while maintaining lowest restriction.



Fuel level at filter wrap level. Even though the fuel level is now more than half of the filter element, the fuel is still flowing through clean media at minimal restriction levels. The filter still has significant life remaining.



The filter element is now completely covered by fuel. At this point, all of the media’s surface area is utilized. Restriction is increasing and the filter element should be changed at the next scheduled maintenance interval.

IMPORTANT SAFETY PRECAUTIONS

WARNING: When diesel fuel is circulated through an operating engine, it can become very hot. To prevent personal injury:

- △ **Scalding hazard!** Do not allow fuel to come in contact with eyes or unprotected skin. Allow the engine and fuel to cool to ambient temperature before replacing the fuel filter or performing service operations which could result in spillage of fuel from the fuel system. If this is not possible, protective equipment (face shield, insulated hat, gloves, and apron) must be worn.
- △ **Fire Prevention!** Heated diesel fuel can form combustible vapor mixtures in the area around the fuel source. To eliminate the potential for fire, keep open flames, sparks or other potential ignition sources away from the work area. Do not smoke during filter replacement or service operations.
- △ **Inhalation Prevention!** Always perform engine or vehicle fuel system maintenance in a well ventilated area that is kept free of bystanders.
- △ The ignition key must be in the **off** position.

FUEL PRO 382 DIMENSIONS

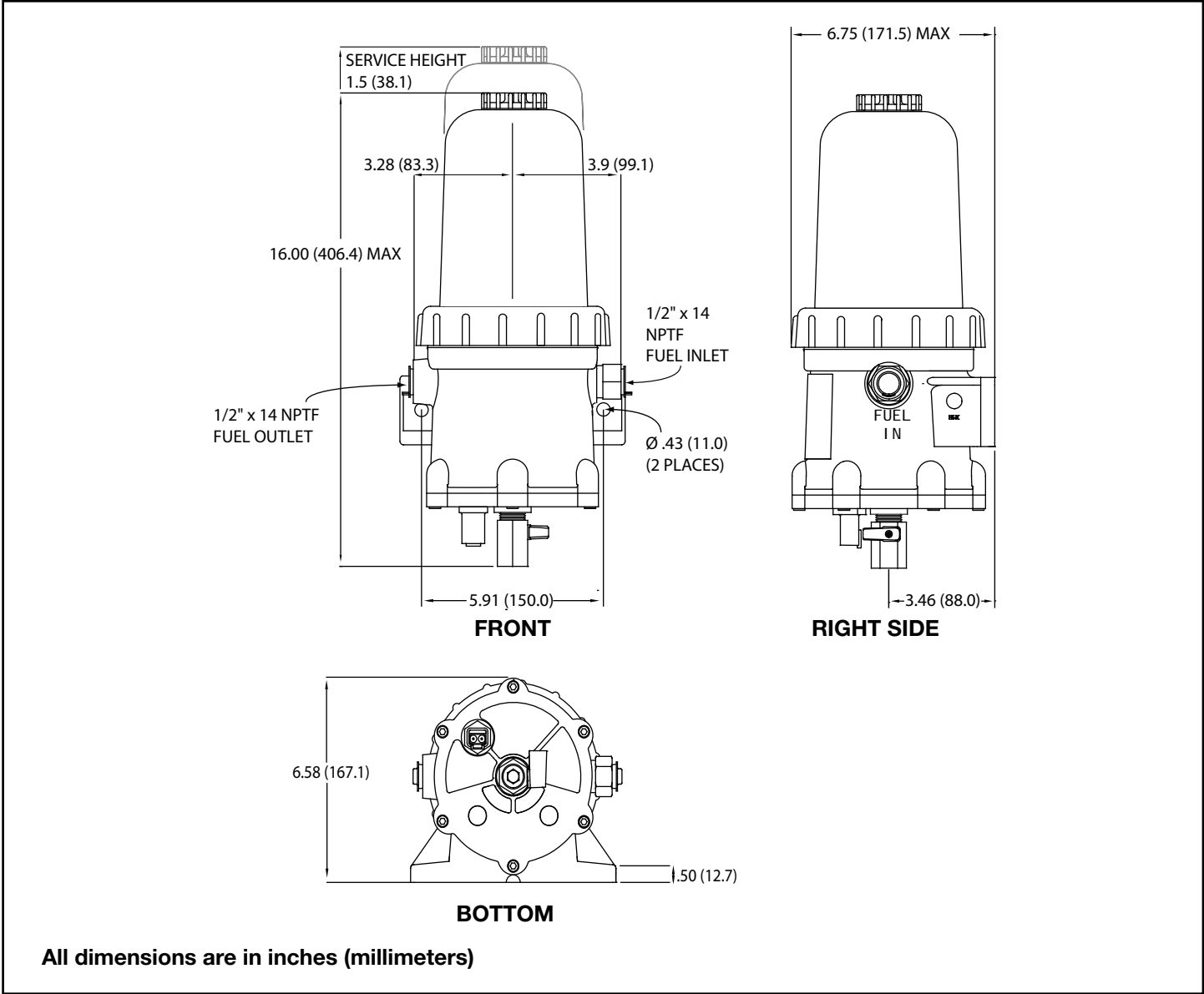

INSTALLATION INSTRUCTIONS

Installation Location

The Fuel Pro must be installed between the fuel tank and the fuel transfer pump. In some cases, the Fuel Pro can be used as the only fuel filter in the system. This is generally dependent on the engine model year. Consult the engine manufacturer for their recommendation. If the Fuel Pro can be used as a single filter, DAVCO offers a diverter cap to replace the secondary filter. (See diverter cap installation section)

Mounting the Fuel Pro

Mount the Fuel Pro keeping the following points in mind:

- Do not install the Fuel Pro directly on the engine.
- Mount vertically with the cover and element pointing up.
- Make sure there is enough top and side clearance for the cover to be conveniently removed for filter replacement.
- The Fuel Pro MUST be installed so that the Filter Element is above the "FULL" level of the fuel tank.

Step 1: With the engine shut down and at ambient temperature, close the fuel shutoff valve (if equipped) and place a suitable container under the fuel filters.

Step 2: Remove the primary fuel filter element assembly, sedimenter, and/or water separator. Drain the used element and dispose of it in an environmentally responsible manner, according to state and/or federal (EPA) recommendations.

Fuel Line Routing

To minimize fuel system restriction, observe the following guidelines when plumbing the fuel system:

- Keep the fuel line routing as smooth as possible with no low-hanging loops which can trap water.
- Use 90° elbows only when necessary.
- If the fuel hoses are cut to length on the job, be sure that the inner liner of the fuel hose is not cut by the fitting, which can cause check valve performance issues. Make sure hoses are clean and free of debris before installing.
- To avoid damaging the aluminum Fuel Pro body, do not overtighten fuel lines or fuel line fittings.

Step 1: Route the fuel supply line from the pickup on the fuel tank to the Fuel Pro inlet (labeled "Fuel In").

Step 2: Route the fuel outlet line from the Fuel Pro outlet (labeled "Fuel Out") to the inlet of the fuel pump.

Priming the Fuel System

Step 1: Check to make sure the drain valve at the base of the Fuel Pro is closed.

Step 2: Remove the vent cap from the top of the clear cover. Fill the Fuel Pro full with clean fuel. Reinstall the vent cap and tighten by hand only.

Step 3: Start the engine. When the lubrication system reaches its normal operating pressure, increase engine RPM to high idle for one to two minutes. After the air is purged loosen the vent cap until the fuel level lowers to just above the collar. Tighten the vent cap by hand only.

Step 4: Hand tighten the collar again while the engine is running. To avoid damage, do not use tools to tighten the collar.

Note: The clear filter cover will not fill completely during engine operation. It will gradually fill over time and the fuel level will rise as the filter becomes contaminated.

INSTALLATION INSTRUCTIONS

Diverter Cap Installation

If a single fuel filter system is approved by the engine manufacturer, the following steps are to be taken to install a diverter cap properly.

Step 1: Select the required secondary filter head diverter cap from those listed in Table 1. The required diverter cap is determined by the size of the spin-on filter stud and the filter sealing surface diameter.

Step 2: Drain and remove the secondary fuel filter element.

Step 3: Lightly lubricate the seal on the top of the diverter cap with clean engine oil.

Step 4: Thread the adapter onto the secondary filter stud and tighten by hand only.

Step 5: Install the “Do Not Remove” label on the diverter cap.

Diverter Cap Part Number	Required Filter Head Stud Size	Required Filter Head Seal ID	Required Filter Head Seal OD
101480	1"-14	2.475"	2.895"
101589	1"-14	3.225"	3.435"
101570	M16 x 1.5	2.475"	2.895"
101466	¾"-16	2.475"	2.895"
101492	7/8" x 14	2.475"	2.895"

Table 1

FLUID HEATER INSTALLATION

The engine return fuel heat and engine coolant heat options apply ONLY to the fluid heater base shown in Figures 2 and 3. If the bottom plate is flat with 1/2" NPT ports, only the electric pre-heater can be used. Contact DAVCO Customer Service to obtain the appropriate bottom plate.

Engine Coolant Heat

To use engine coolant as the Fuel Pro heating fluid, connect a hose (5/8" silicon heater hose) from the high pressure side of the engine coolant system to the Fuel Pro heater base. Either heater port will work as an inlet. Route another hose from the heater base to a low pressure port in the coolant system. DO NOT route into the cab heater system. (See Figure 2)

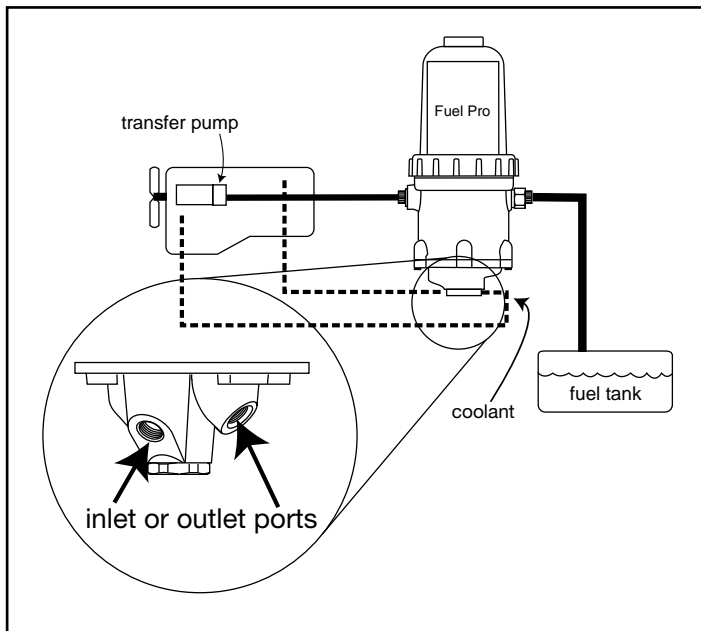

Figure 2

Engine Return Fuel Heat

High flow and high temperature return fuel engines can use the return fuel as the heating fluid for the Fuel Pro. Route the return fuel line from the engine into the heater base of the Fuel Pro. Either heater port will work as an inlet. Connect a second fuel return line from the heater base to the fuel tank return port. (See Figure 3)

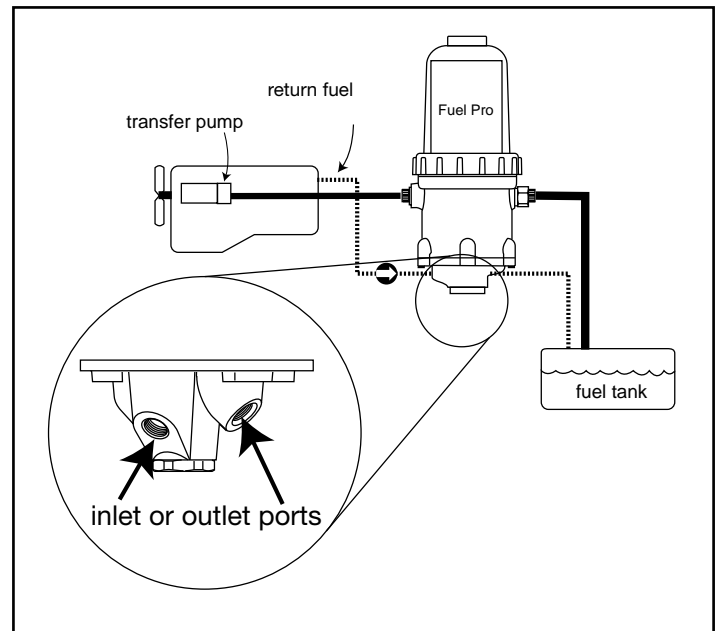

Figure 3

12 VDC AND 24 VDC ELECTRIC PRE-HEATER INSTALLATION

Installing 12 VDC and 24 VDC Electric Pre-heaters

The Fuel Pro 382 12 VDC or 24 VDC electric pre-heater is installed in the processor base as shown in Figure 4.

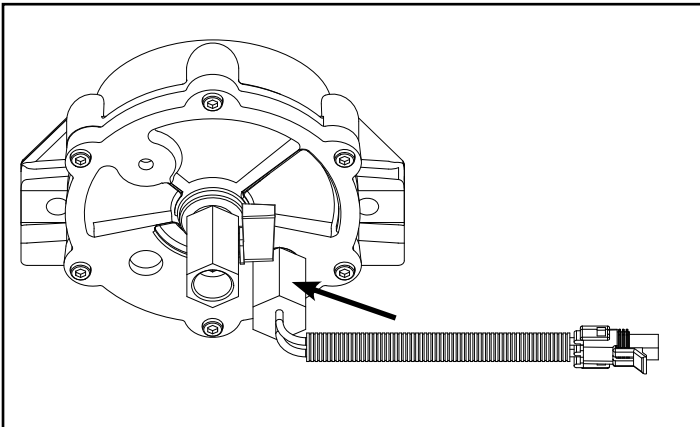

Figure 4

Step 1: Drain all the fuel from the Fuel Pro. The fuel can be reused after the pre-heater is installed. If the fuel is not reused, dispose of it in an environmentally safe way.

Step 2: Remove the pipe plug in the Fuel Pro base plate.

Step 3: Apply liquid thread sealant to the pre-heater threads and install into the Fuel Pro base. Tighten to 15-30 ft-lbs.

Step 4: Connect the chassis harness and wire.

- For 12 VDC or 24 VDC without a relay, refer to Figure 5.
- For 12 VDC or 24 VDC with a relay, refer to Figure 6.
- If the keyed circuit will not handle a minimum of 20 amps, use a relay.
- Provide proper (20 amp fuse) electrical protection for source voltage supplied to the pre-heater.

Step 5: Remove the vent cap from the top of the clear cover. Pour fuel into the Fuel Pro to one inch below the top of the filter element. Reinstall the vent cap and hand tighten.

Step 6: Start the engine. When the lubrication system reaches its normal operating pressure, increase engine speed to high idle for one to two minutes. After the air is purged, loosen the vent cap until the fuel level drops to just above the collar. Tighten the vent cap by hand only.

Pre-heater Wiring without Relay

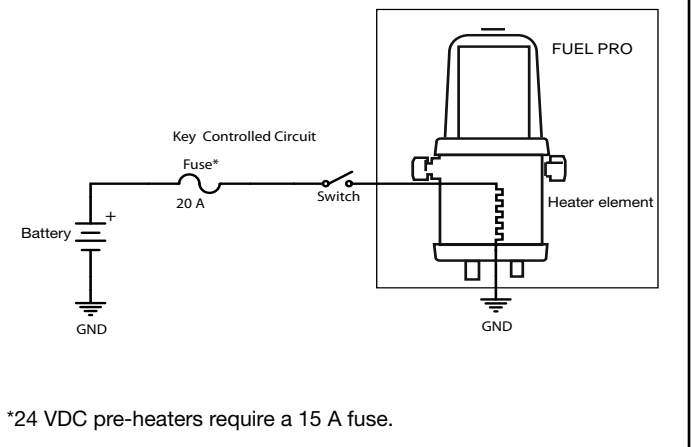

Figure 5

Pre-heater Wiring with Relay

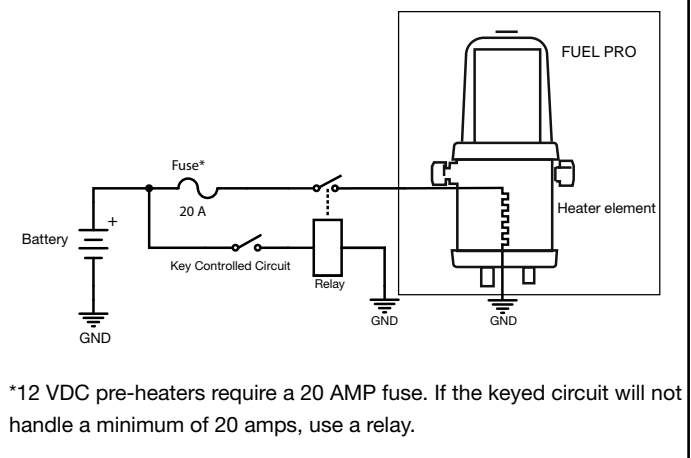

Figure 6

WATER IN FUEL SENSOR (WIF) INSTALLATION

Step 1: Remove the ½"-20 WIF plug in the bottom of the Fuel Pro.

Step 2: Install the WIF Probe (See Service Parts Page for P/N) into the bottom of the Fuel Pro. Torque to 20-24 in-lbs.

Step 3: Install the WIF wiring harness (P/N 102600) on WIF Probe. The harness has the following connections: black ground lead with a 3/8" diameter ring terminal and a green WIF wire.

Step 4: Drill ½" hole in the instrument or control panel where the WIF indicator light is to be located.

Step 5: Connect the black ground wire from the WIF indicator light to a ground source. Attach additional black wire as needed.

Step 6: Install the WIF indicator light by pressing firmly into the drilled hole.

Step 7: Connect the black ground lead with a 3/8" diameter loop end on the WIF wiring harness to the ground source near the Fuel Pro (if applicable).

Step 8: Connect the green signal wire on WIF wiring harness to green signal wire on WIF indicator light. Use additional green wire as needed.

Step 9: Locate 12 VDC or 24 VDC key controlled on power source. Install a red wire from the power source to the red wire on WIF indicator light. Add a 1 amp in-line fuse (not included).

Note: Use appropriate connectors to attach the wires. To test the WIF indicator light, pour water into the body of the Fuel Pro until it covers the WIF probe. The WIF indicator light should illuminate.

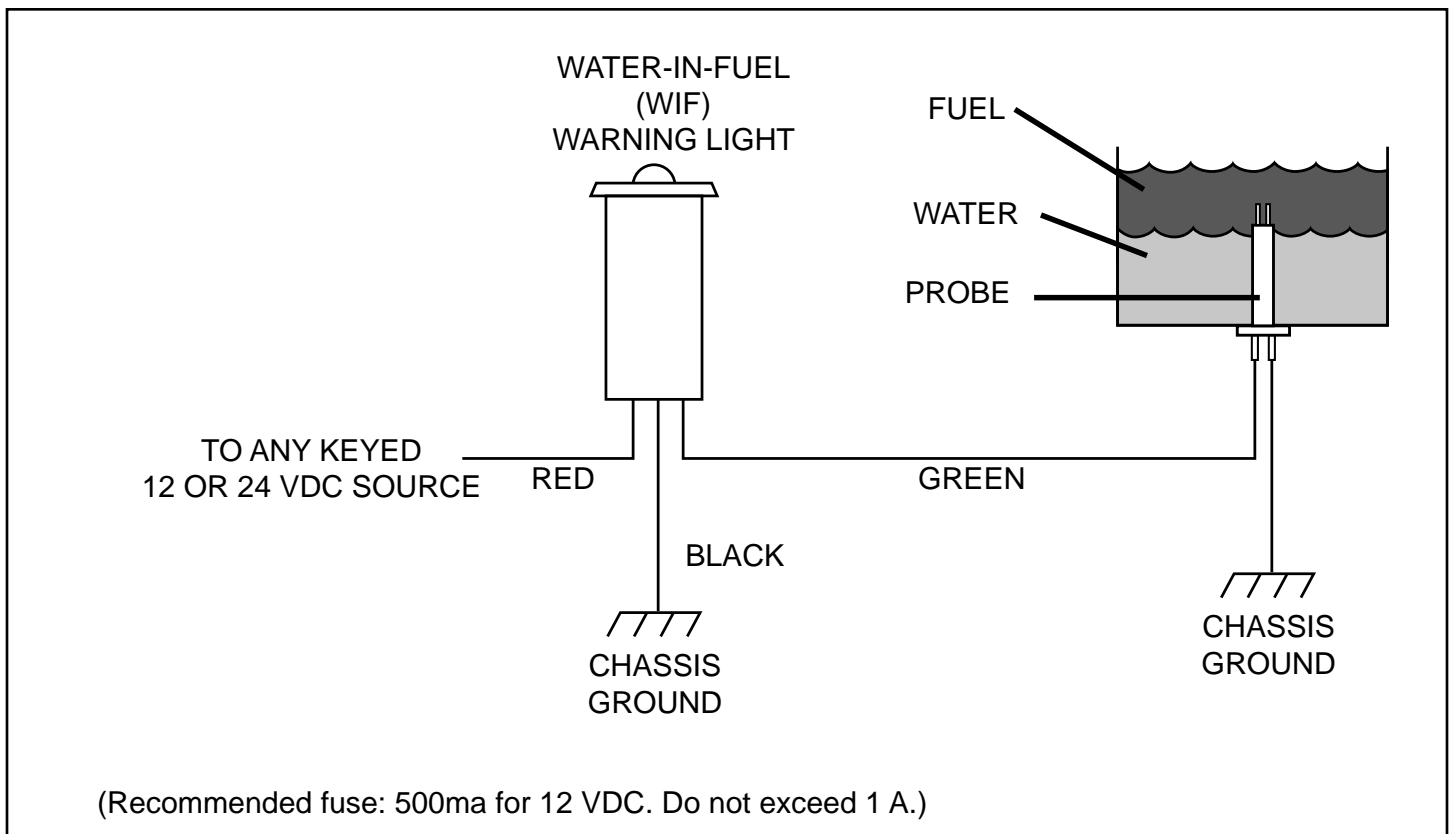

PREVENTIVE MAINTENANCE

- **Weekly – Drain water**
 - Turn off the engine and open the vent cap.
 - Place a suitable eight ounce, plastic or metal container under the drain valve at the base of the Fuel Pro and open the valve.
 - Water will flow into the container. When fuel begins to flow out the drain, close the drain valve. Drain the least amount of fuel as possible.
 - **Hand-tighten** the vent cap.
 - Start the engine. Raise the RPM for one minute to purge the air from the system.
- **Every filter change**
 - Change the cover and vent cap o-rings (included with the service filter kit).
- **Every 12 months**
 - Check all electrical connections for corrosion. Check all fuel fittings for leaks.
- Extreme winter or salt corrosion environments may require lubrication of the collar threads with anti-seize lubricant every 180 days.

FILTER CHANGE PROCEDURE

Filter Change

For filter selection visit www.davco.com/parts.html (Parts And Cross Reference) for the correct filter for your application or call DAVCO Customer Service at 800-328-2611.

Step 1: Remove the vent cap and open the drain valve to drain the fuel below the collar level.

Step 2: Remove the collar (using the DAVCO collar wrench) then remove the clear cover.

Step 3: Remove the filter, cover and vent cap seals. Dispose of the filter and the seals properly.

Step 4: Using a clean shop rag, clean the cover, the collar and threads on the Fuel Pro body.

Step 5: Install a new filter, cover seal and vent cap seal.

Step 6: Reinstall the clear cover and collar. **Hand tighten the collar.**

Step 7: Prime the unit by filling the clear cover with clean diesel fuel until it reaches the top of the filter.

Step 8: Install the vent cap. **Hand tighten only.**

Step 9: Start the engine and run for one minute. **Slowly** open the vent cap and allow the fuel to drop to about one inch above the collar.

Step 10: Close the vent cap. **Hand tighten only.** It is normal for the fuel level to vary after the initial start-up and during engine operation. Filter performance is not affected.

Service Wrench Information

- The DAVCO Fuel Pro vent cap and collar are designed to be removed with a DAVCO wrench.
- Vent caps and/or collars damaged as a result of not using the DAVCO wrench will not be covered under warranty. Wrench is for removal ONLY.

Description	P/N
Metal Collar/Vent Cap Wrench	380134
Composite Collar/Vent Cap Wrench	382002

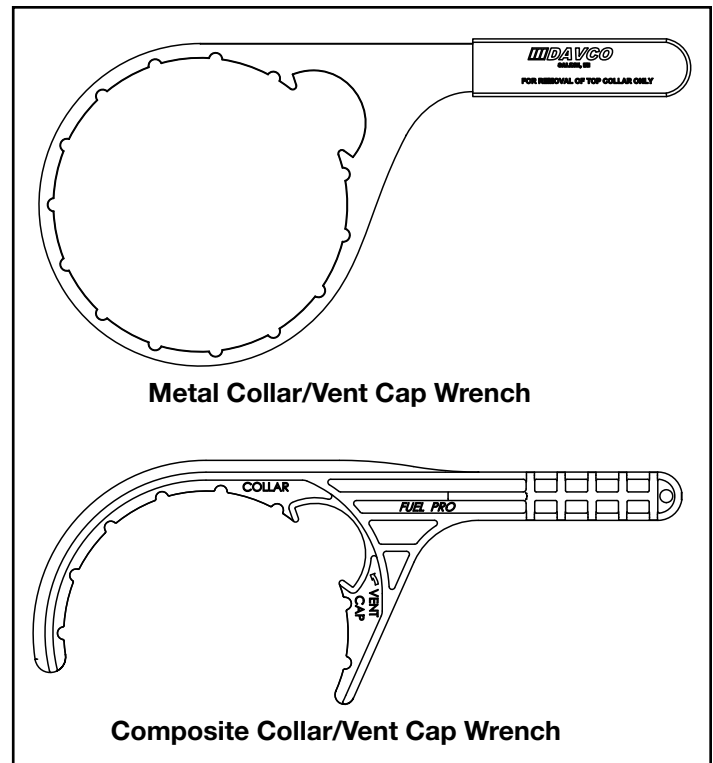

VISUAL DIAGNOSTICS

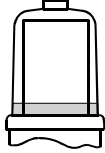
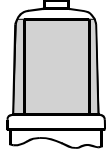
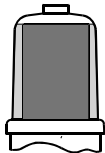
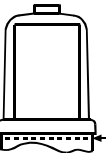
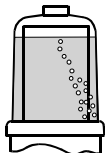
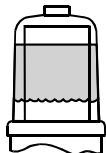
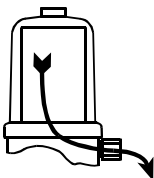
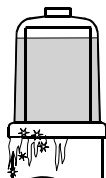
<p>Fuel level is not at the top of the fuel filter. → Normal - Do not change the filter.</p>		<p>Fuel level is at the top of the filter. Low power. → Change the filter at the first available opportunity.</p>	
<p>Fuel level is at the top of the filter and appears to be full of wax. → Change the filter - Run the engine for a minimum of 25 minutes at idle. Do not run at full RPM.</p>		<p>There is a power complaint and the fuel level is below the collar. → Check for a missing grommet at the lower end of the filter or missing/broken spring at top of filter.</p>	
<p>Bubbles are seen flowing in with the fuel. → Check all fittings and lines from the fuel tank to the fuel processor. Check lower and upper collar o-rings.</p>		<p>Water is noticed in the cover. → Drain the water. If engine coolant is visible, follow proper engine pressure testing procedures to determine root cause.</p>	
<p>Fuel drains back to the fuel tank when changing the fuel filter or draining separator. → Remove the check valve assembly. Clean or replace and retest. Check air leaks in the fuel system.</p>		<p>No engine coolant flow to the Fuel Pro heater. → Check for closed cutoff valves at the coolant lines to the fuel processor. Make sure the cab heater valve is open.</p>	

VISUAL DIAGNOSTICS

There are two kinds of bubbles that may be visible at the fuel pump inlet of a diesel fuel system. The bubbles can be characterized as either air bubbles or vapor bubbles.

Air Bubbles (will affect engine performance)

Air bubbles are caused by any air leak on the vacuum (suction) side of the fuel system from the fuel tank pick-up to, and including, the lift pump. (See Figure 7)

If there is an air leak in the fuel system, air bubbles will be present in the clear cover of the Fuel Pro. Follow test procedures outlined in "Troubleshooting" for air leak diagnostics.

If there are no bubbles present in the Fuel Pro cover and the engine continues to run rough, lopes or has a loss of power, there may be an air leak between the Fuel Pro outlet port and lift pump inlet. This type of air bubble can be seen if a sight tube is installed at the lift pump inlet. Air bubbles may also be visible in the fuel return (spill) hose out of the fuel gallery. These leaks are easily eliminated by checking and torquing the fuel fittings in the area of the leak.

If there are no air leak symptoms, but bubbles are present in a sight tube at the fuel lift pump inlet, they are most likely vapor bubbles.

Note: A quick procedure to determine if the air leak is between the fuel tank and the Fuel Pro is to remove the Fuel Pro inlet hose and route a new hose from the Fuel Pro inlet into a container of fuel or the fuel tank fill cap opening. Start the engine and check for bubbles.

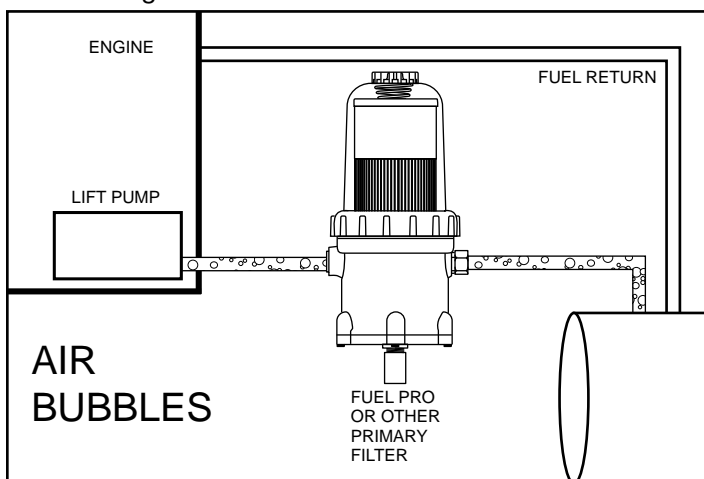

Figure 7

Vapor Bubbles (will not affect engine performance)

All diesel fuel has some level of entrained air caused by the natural splashing that occurs in the fuel tank during normal vehicle or equipment operation. Vapor bubbles develop in the Fuel Pro because the pressure inside the Fuel Pro is lower than the atmospheric pressure in the fuel tank. Vapor bubbles can vary from champagne size up to 1/4" in diameter. They may increase in size or volume as engine RPM increases. The lower pressure draws the entrained air/vapor out of the fuel and these bubbles will be visible as the fuel exits the Fuel Pro. (See Figure 8)

As the fuel enters the lift pump, it is pressurized and the bubbles are compressed back into the fuel. There will be no bubbles on the fuel return side of the system. (See Figure 8). These vapor bubbles will not affect the performance of the engine.

There is no diagnostic or repair procedure required for vapor bubbles. Vapor bubbles do not cause performance issues and will not be present after the lift pump.

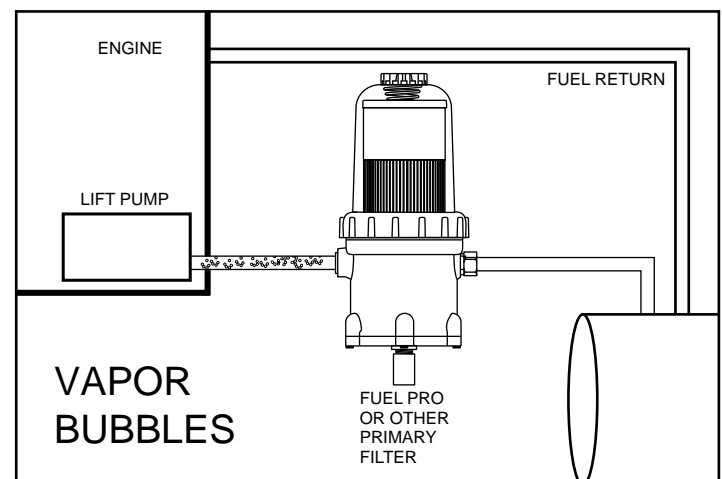

Figure 8

DIAGNOSTIC PROCEDURES

Air Leaks

Every Fuel Pro is factory tested for leaks and is identified with a traceable number prior to shipment. Most field issues associated with leaks are related to loose fittings. These leaks are easily eliminated by checking and torquing the fuel fittings in the area of the leak. Some fittings may also require the application of liquid Teflon sealer.

Note: All suction side fuel filters experience bubbles. It is normal to see champagne size bubbles in the Fuel Pro cover, at the Fuel Pro outlet or at the lift pump.

IN ORDER TO RETURN A FUEL PRO FOR EVALUATION, THE FOLLOWING PROCEDURES/TESTS MUST BE COMPLETED BEFORE REQUESTING A DAVCO RGA (RETURN GOODS AUTHORIZATION) NUMBER.

- I. **Air Leak:** Air bubbles will be visible in the clear cover of the Fuel Pro if the leak originates between the fuel tank up and the fuel filter. The following is a quick test to isolate the air leak source.
 - A. **Bubbles Visible:** Remove the Fuel Pro inlet hose.
 - i. Install a jumper hose from the Fuel Pro to the fuel tank (through the fill cap) or to a container of fuel.
 - ii. Start the engine. If this eliminates the air bubbles, the air source is at the fuel tank fittings or hose connections.
 1. Tighten all fittings and connectors
 2. Retest
 - iii. If air bubbles persist, the air source is on the Fuel Pro side of the system:
 1. Tighten all fittings on the Fuel Pro .
 2. Hand tighten the top collar.
 3. If the drain valve is suspected, install a plug in place of the drain valve (for test purposes only).
 - iv. If air bubbles continue to persist, test as follows:
 1. Remove the Fuel Pro from the chassis.
 2. Plug the fuel outlet port. Do not remove filter, cover/collar, vent cap, drain valve and/or check valve. If the Fuel Pro is equipped with a pre-heater, do not remove the pre-heater.
 - B. **Bubbles Not Visible:** If there are symptoms of sucking air (indicated by engine loping/rough running performance/power loss, etc.) and there are no bubbles in the clear cover, the air leak is either at the Fuel Pro outlet fitting, vent cap o-ring, the lift pump inlet connection, or the fuel hose/connections to the lift pump. Inspect and tighten fittings as needed.
- II. **Excessive Restriction:** If the fuel level is at the top of the filter, replace the fuel filter. The Fuel Pro will not cause excess system restriction if the fuel level is below the top of the filter. The only exception is if the grommet is not installed in the bottom of the filter element.
- III. **Loss of Prime:** When air is introduced into the fuel system, (i.e. draining water from the Fuel Pro or when replacing the fuel filter) a check valve is needed to keep the fuel system primed from the Fuel Pro back to the fuel tank. A check valve is standard with every Fuel Pro
 - A. To test for proper check valve operation, remove the fuel inlet hose and open the vent cap. Fuel should not flow out of the Fuel Pro , although a slight seepage of fuel is normal.
 - B. If fuel drains back to the fuel tank, remove the check valve assembly at the fuel inlet fitting. Disassemble the check valve assembly. Clean and inspect. Replace the assembly if any cuts, grooves or nicks are evident in the ball or body seat. Reinstall the check valve assembly.

DIAGNOSTIC PROCEDURES

Fluid Heater Thermovalve Test

Step 1: Drain the Fuel Pro completely.

Step 2: Remove the fluid hoses going to the bottom plate. These will either be engine coolant hoses or return fuel hoses. Engine coolant hoses will have to be plugged when removing them from the Fuel Pro.

Step 3: Remove the bottom plate.

Step 4: While looking into the fluid port of the bottom plate (see Figure 9) flow cold water over the thermovalve for 30 seconds, then run hot water over the thermovalve and determine if the thermovalve spool is opening and closing.

Step 5: Replace with a new bottom plate seal and install the bottom plate onto the Fuel Pro.

Note: There are two styles of bottom plates.

- Torque the collar version to 50 to 60 ft-lbs (the use of 2-3 drops of Loctite 406 is recommended to secure the bottom collar). Use seal P/N 101994.
- Torque the bolts on the bolt-on version bottom plate to 10 ft-lbs. Use seal P/N 910005.

Step 6: Reconnect the fluid hoses to the bottom of the Fuel Pro.

Step 7: Fill the Fuel Pro with fuel and restart the engine.

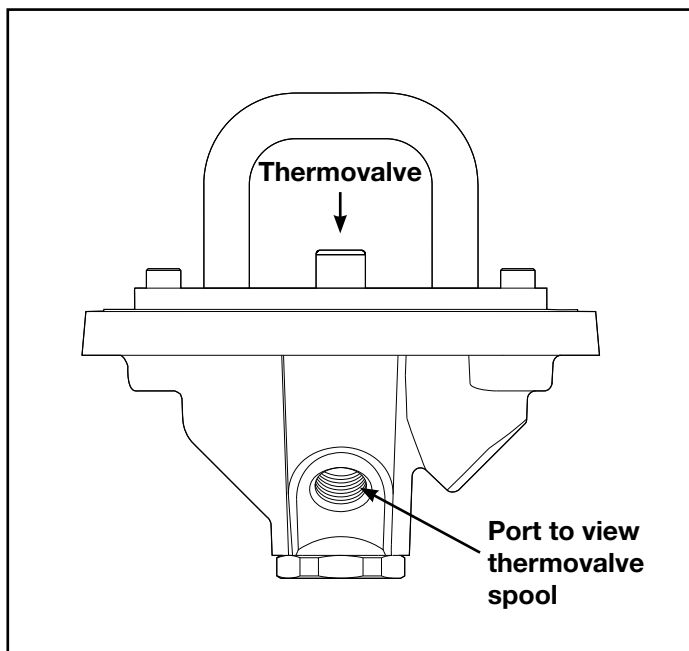

Figure 9

Electric Pre-Heater and Thermostat Tests

Equipment Needed:

- A precision low resistance Ohm Meter capable of measuring 1/10th Ohm or less is recommended.
- Current Flow Meter (Clamp-on type for DC current).
- Ice, dry-ice, CO₂ or some means of chilling the thermostat.
- A flameless source of heat. Infrared heat lamp, etc. (a Vortex tube is a good tool to heat and cool for testing).

⚠ DO NOT USE a test light that has a wire probe for any of these tests. If the insulation of the wiring is punctured, moisture and road salt can penetrate into the wires creating a corrosion issue and potential failure.

There are various configurations of electric pre-heaters and thermostats available for the Fuel Pro. These include 12 VDC pre-heaters, 24 VDC pre-heaters, 120 VAC pre-heaters, thermostat, and combination pre-heater thermostat. The voltage and wattage ratings are stamped either on the sheath or the hex of each component for identification.

If it is necessary to remove the fuel from the fuel/water separator:

- Shut off the engine and set the parking brake.
- Attach a length of hose to the drain valve and into a container.
- Loosen the vent cap on top of the clear housing, and open the drain valve to drain the fuel into the receptacle.
- When the fuel is drained, close the drain valve.

Pre-heater Test

Step 1: Disconnect the pre-heater from the harness.

Step 2: Connect the Ohm meter leads to the pins of the pre-heater (connect to a pin and the bushing for pre-heaters with one pin).

Step 3: Using the Table 2, read the value of the resistance and determine if the pre-heater is within the acceptable range.

DIAGNOSTIC PROCEDURES

Electric Pre-heater	Watts	Resistance Range in Ohms
12 VDC (two pin)	250 W	0.6 to 0.8
12 VDC (single pin)	250 W	0.6 to 0.8
12 VDC (single pin)	150 W	0.8 to 1.1
12 VDC (two pin)	150 W	0.8 to 1.1
24 VDC (two pin)	250 W	2 to 2.5
24 VDC (single pin)	250 W	1.8 to 2.3
24 VDC (single pin)	150 W	3.6 to 4.1
120 VAC	75 W	173 TO 203
120 VAC	37 W	369 TO 411

Table 2

12 VDC Thermostat Test

Step 1: Disconnect the thermostat harness (see Figure 10).

Step 2: Connect the Ohm meter leads to the pins of the thermostat.

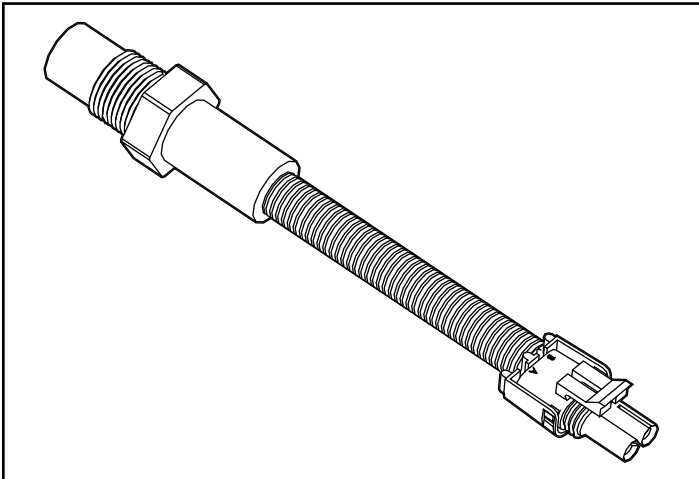

Figure 10

Note: This test requires the thermostat to be below 40° F. (Use one of the cooling sources listed under "Equipment Needed".) The resistance should be less than 0.1 Ohm.

Step 3: Using one of the heat sources listed under "Equipment Needed", raise the temperature above 60° F. The resistance should be more than 10M Ohms.

Step 4: Prime the unit by filling the clear cover with clean

diesel fuel until it reaches the top of the filter.

Step 5: Install the vent cap. **Hand tighten only.**

Step 6: Start the engine and run for one minute. **Slowly** open the vent cap and allow the fuel to drop to about one inch above the collar. Close the vent cap. **Hand tighten only.**

CHECK VALVE DIAGNOSTICS

To test for proper check valve operation, remove the fuel inlet hose and open the vent cap. Fuel should not flow out of the Fuel Pro, although a slight seepage of fuel is normal. If fuel drains back to the fuel tank, remove the check valve assembly at the fuel inlet fitting.

Step 1: Use a back-up wrench to hold the check valve body and remove the fuel hose from the inlet of the Fuel Pro.

Step 2: Remove and disassemble the check valve assembly.

Step 3: Clean and inspect the check valve body. Replace the check valve body if any cuts, grooves or nicks are evident or if the ball seat is not smooth.



Step 4: Inspect the check valve spring and spring retainer. If the spring or spring retainer is broken or if the check ball has grooves, nicks or is out of round, replace with a check valve service kit. Otherwise, clean and reassemble the check valve assembly.

Note: The spring retainer snaps into a groove in the check valve body.

Step 5: Replace the check valve assembly into the body and torque to 44-60 ft-lb.

Step 6: . Connect the fuel inlet hose, using liquid or paste type thread sealant.

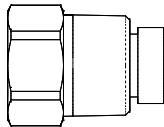
Step 7: Prime the fuel system, start the engine and check for any fuel leaks.

Check Valve Body	Check Valve Service Kit
	
P/N 090037	P/N 101132



SERVICE PARTS

Visit www.davco.com for OEM service part number listing.

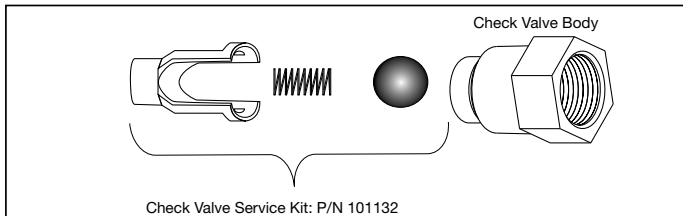
Service Parts	
Description	Part Number
Collar	102425
Clear Cover	102420
Spring	380056
Filter Element	visit www.davco.com/parts.html for filter ordering information.
Drain Valve	102008
Electric Pre-heaters	visit www.davco.com , Form F1263
WIF	See Page 20
Check valve body	090037
Spin-on stud 13/16" -12 (Yellow Zinc)	320620



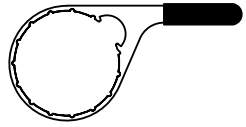

Service Kits		
Description	Contents	Part Number
Vent cap service kit	Vent cap and Vent cap O-ring	380043
O-ring service kit	Vent cap and Cover O-rings	380072
Check valve service kit	Retainer, spring and ball (does not include the check valve body)	101132

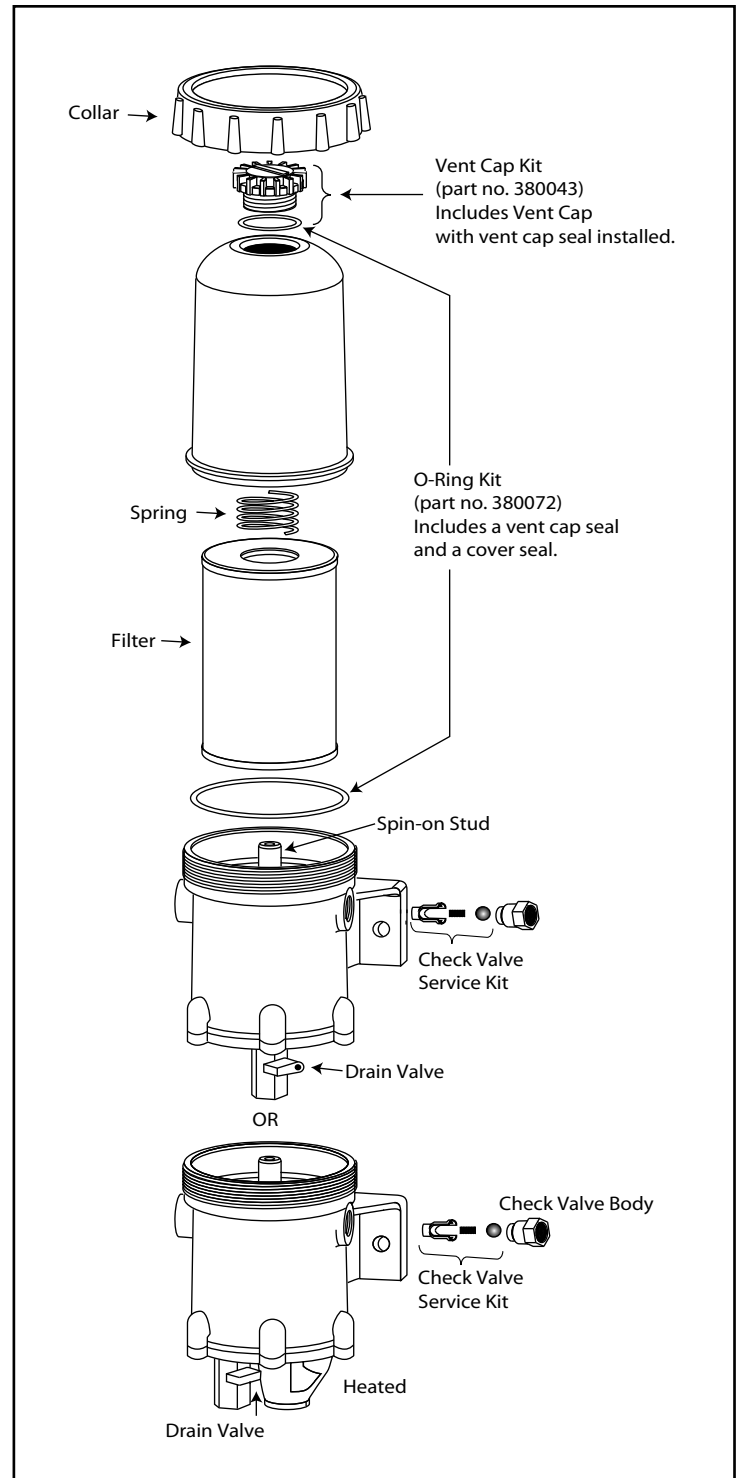
DAVCO Wrenches		
Description	Part Number	
Metal Collar/Vent Cap Wrench	380134	
Composite Collar/Vent Cap Wrench	382002	



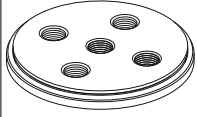
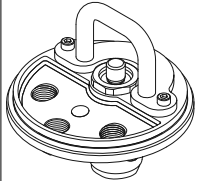
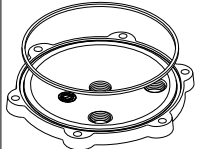
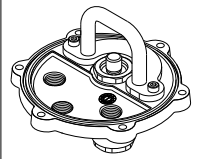
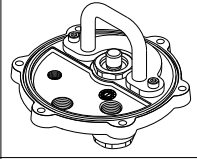
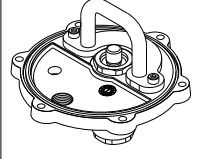
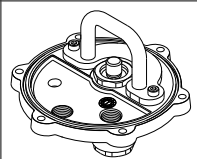
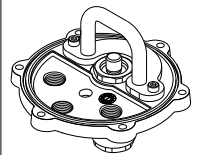

SERVICE PARTS

Bottom Plate - Service Kits and Parts			
Description	Part Number		
Seal (Bottom Collar)	101994		
Seal (Bolt-On)	910005		
Unheated Bottom Plate (Bottom Collar)	382006SVC		
Fluid Heated Bottom Plate (Bottom Collar)	382015SVC		
Unheated Bottom Plate (Bolt-On)	382027SVCB		
Bottom Plate Upgrade Includes: Radiator o-rings (2) Thermo-Valve Assembly Bottom plate seal (square cut) Spool assembly Bottom plate plug w/o-ring	382029SVCB	Standard	
	382029SVCBE	With ESOC port	
	382029-5SDAV	With 1/2-20 WIF port and 3/8" Fluid Port	
	382029-14DAV	With 1/2-20 WIF, 3/8" Fluid Ports and Heater Port	
	382029NAV	Navistar Bottom Plate with 9/16" Fluid Heat, Heater and WIF ports	

Visit www.davco.com for OEM service part number listing.

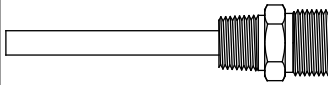
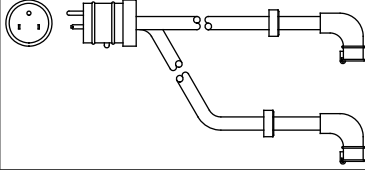
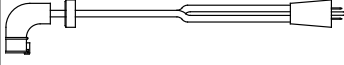
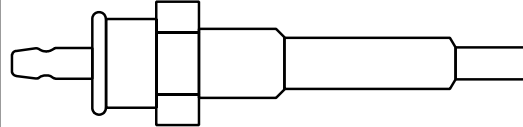
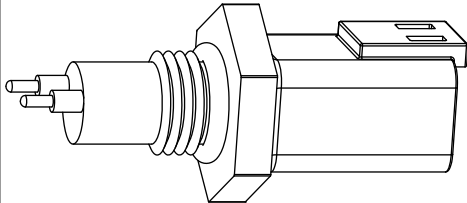
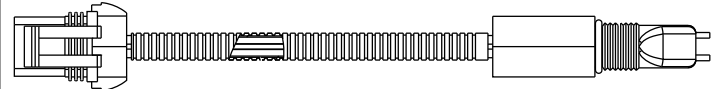
SERVICE PARTS

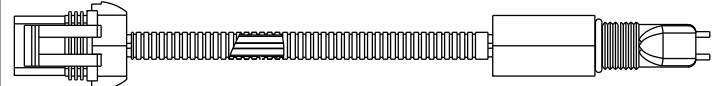
Pre-heater - Service Parts		
120 VAC Preheater	102145	
120 VAC "Y" Cord	102015	
120 VAC Straight Cord	101868	
<p>*Note: Visit www.davco.com, Form F1263 for 12 VDC and 24 VDC Pre-heaters. For Specific OEM numbers for pre-heaters, contact customer support at 1-800-328-2661.</p>		
Water-in-Fuel (WIF) Service Parts		
1 Pin WIF sensor	101017	
2 Pin WIF sensor (Fleetguard and Bus Applications)	102507	
2 Pin WIF harness (17" Freightliner Chassis) Metripak	102519	
2 Pin WIF harness Deutsch (Grey)	102512	
2 Pin WIF harness Deutsch (Black)	102521	
2 Pin WIF	102770	

Visit www.davco.com for OEM service part number listing.

WARRANTY AND CUSTOMER SERVICE

PRODUCT WARRANTY

Fuel Pro 482, Fuel Pro 382, Diesel Pro 243, Industrial Pro, Shop Pro, Pro-Chek, Sea Pro and REN Products

DAVCO Technology, LLC warrants these products to be free of defects in material and workmanship for 5-years, 500,000 miles or 10,000 hours (whichever comes first) and electrical parts for 2-years, 200,000 miles or 4,000 hours (whichever comes first) from the purchase date. Shop Pro Motor has a one year warranty from the date of purchase.

EyeMax, Electronic Gauges, Electronic Dipsticks, Fuel Pro 384

DAVCO Technology, LLC warrants these products to be free of defects in material and workmanship for 2-years or 200,000 miles (whichever comes first) from the purchase date.*

Limitation:

- DAVCO is not responsible for failures resulting from misuse, misapplication, faulty installation, alteration, poor maintenance, neglect or accident.
- DAVCO is not responsible for downtime, loss of profits or income, living expenses, or other incidental, special or consequential damages.
- This warranty is the sole warranty made by DAVCO.
- DAVCO makes no other warranties, expressed or implied, of merchantability or fitness for a particular purpose.
- DAVCO does not warranty any aftermarket or OEM component not approved specifically to work with a DAVCO manufactured product.

In the event of a defective product, DAVCO will either rework the defective product or replace it at DAVCO's discretion. If you feel you have a warrantable issue, contact DAVCO at 800-328-2611 for a Return Goods Authorization (RGA) number. An RGA number is required **prior** to the return of any product.

*Purchase Date: The date of the first retail purchase of a new vehicle or piece of equipment from the OEM dealer or factory. For "Over the Counter" purchases: The date of the sale of a DAVCO product to the first retail customer.

PARTS RETURN GENERAL POLICY

Note: A Return Goods Authorization (RGA) must be obtained from DAVCO prior to returning any products. Returns may be accepted under the following circumstances:

Order Shipping Error: A credit against the original invoice, including freight charges for both ways will be issued for returns in which DAVCO inadvertently shipped incorrect quantity or product.

Overstock: Returns for ordering more product(s) than required, or incorrect part(s), will be accepted within 60 days from the date of purchase. Proof of purchase will be required, IE: original invoice/delivery receipt. These types of return(s) are subject to a minimum restock fee of 40% or \$40.00, whichever is higher. Additional restock fees may apply. Product(s) will be inspected for "like new" condition and additional costs will be the responsibility of the customer. No obsolete parts may be returned.

Freight charges for return(s) will be the responsibility of the customer.