

DIMENSIONS

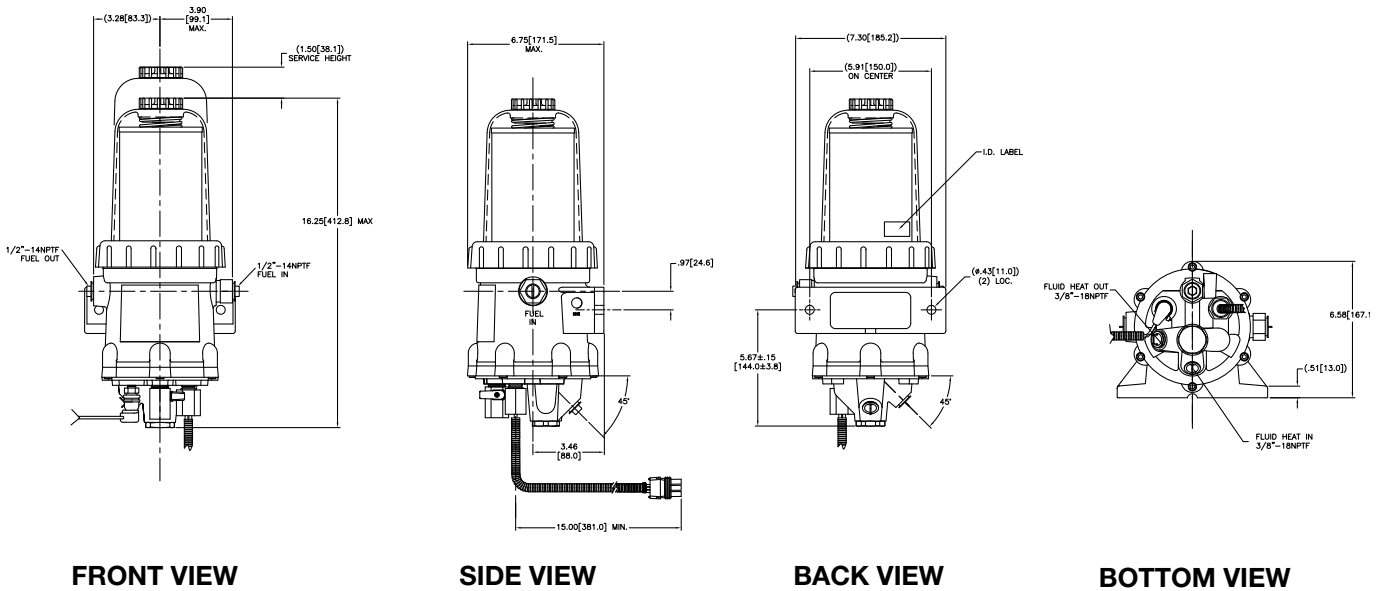

OPTIONS/FEATURES

- Water In Fuel Sensor (WIF)
- Electric Pre-heaters
 - 12 VDC
 - 24 VDC
 - 120 VAC

PRODUCT SPECIFICATIONS

Height Overall	16.25 in (412.8 mm)
Depth Overall	6.58 in (167.1 mm)
Width, max.	7.3 in (185.2 mm)
Mount Bracket Centers	5.91 in (150 mm)
Weight, dry	8-12 lbs
Fuel In Connection	3/4"-14 NPTF
Fuel Out Connection	3/4"-14 NPTF
Filter Service Clearance Min	1.5" (38 mm)
Max Fuel Flow	180 gph
Electric Pre-heater	12 VDC, 250 W, 18 A
	24 VDC, 250 W, 12 A
	120 VAC, 75 W, .65 A
Fluid Heater Connection	3/8"-18 NPTF

FILTRATION PERFORMANCE

FUEL PRO 382 AT 120 GPH

Micron	Coarse Water Removal (%)	Emulsified Water Removal (%)	Dirt Holding Capacity (grams)
7 mic	99.4	80.5	70
10 mic	99.8	95.5	85
25 mic	99.6	97.8	110
50 mic	97	<20	90

RESTRICTION VS. FLOW

