

This is a replacement kit for a Davco Fuel Pro® 382/384 or Industrial Pro® wire harness, thermo switch, and heater, to a combination Heater/Thermo Switch assembly. A replacement seal for the bottom plate and a pipe plug is included.

FOLLOW THESE INSTRUCTIONS CAREFULLY:

1. Drain all fuel from the Fuel Processor. Dispose of it in an environmentally responsible manner.
2. Disconnect and remove the chassis harness, thermo switch, and heater. (If necessary, remove the bottom plate from the unit for ease of assembly/disassembly).
3. Apply pipe sealant to threads of pipe plug and the new Combination heater/thermo switch and install into the bottom plate. If the bottom plate was removed, replace the seal (round style for bottom collar, square style for bolt-on) and reinstall. Torque bottom collar to 50-60 ft lbs or screws to 10-12 ft lbs.
4. Connect the Combo Heater harness to the chassis power connector.
5. Start engine, when the lubrication system reaches it's normal operating pressure, increase the engine RPM for on minute. Slowly open vent cap until fuel level drops to one inch above collar. Hand tighten vent cap.



COMBO THERMO SWITCH

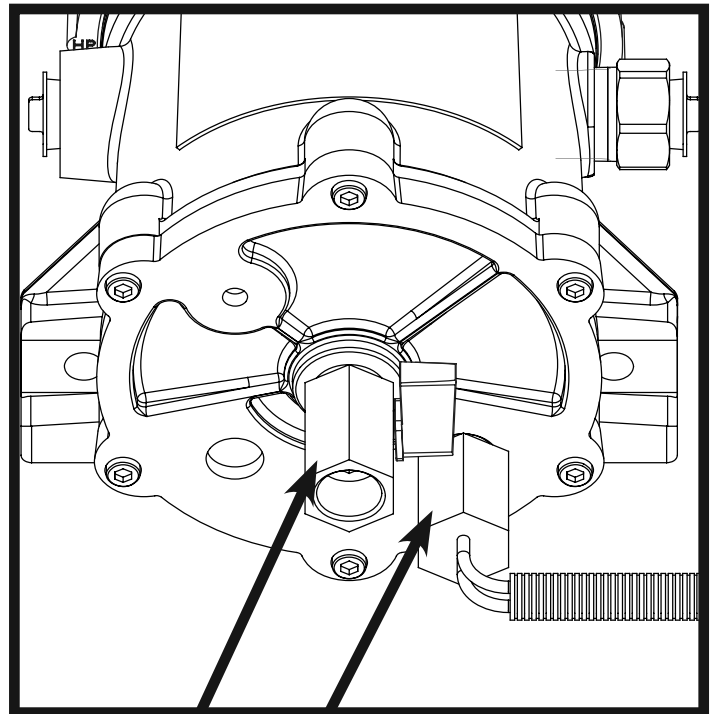

COMBO THERMO SWITCH HEATER

DRAIN VALVE

Replacing a 12 VDC Weather Pak Connector

OBSOLETE PART NUMBERS	REPLACEMENT PART NUMBERS
12 VDC Fuel Pro Heater: 102166	
12 VDC Industrial Pro Heater: 102463	
12 VDC 3 Wire Heater: 102406	
12 VDC Thermo Switch: 102453	
12 VDC 3 Wire Thermo Switch: 102398	
12 VDC Harness: 102455	
12 VDC 3 Wire Harness: 102406	

Replacing a 24 VDC Weather Pak Connector

OBSOLETE PART NUMBERS	REPLACEMENT PART NUMBERS
24 VDC Fuel Pro Heater: 102168	
24 VDC Industrial Pro Heater: 102464	
24 VDC 3 Wire Heater: 102399	
24 VDC Thermo Switch: 102454	
24 VDC 3 Wire Thermo Switch: 102398	
24 VDC Harness: 102455	
24 VDC 3 Wire Harness: 102399	

Old Style



New Style



Replacing a 12 VDC Metri Pak Connector

OBSOLETE PART NUMBERS	REPLACEMENT PART NUMBERS
12 VDC Heater: 102166	
12 VDC Thermo Switch: 102453	
12 VDC Harness: 102465	
12 VDC 3 Wire Thermo Switch: 102398	
12 VDC 3 Wire Harness: 102407	

Old Style



New Style



Replacing a 12 VDC Pre-Heater for Fuel Pro 380

OBSOLETE PART NUMBERS	REPLACEMENT PART NUMBERS
12 VDC Heater: 380636	
12 VDC Thermo Switch: 103033	
12 VDC Harness: 101204	

Old Style



New Style

